



CREO Light.
Light years ahead.



**Inground Light
UL01F 1.5W 24V
WW IP68**



PRODUCT HIGHLIGHTS

- ~ Recessed fitting for ground installation for outdoor and indoor use
- ~ High brightness LED light with consistent colour temperature
- ~ Body made of sand casting stainless steel "316L"
- ~ ABS installation housing. 0.5 meter of waterproof cable connector
- ~ Long service lifetime of 30'000 hours
- ~ No UV or IR emissions. No mercury

GENERAL CHARACTERISTICS

Product Name	LD UL01F 1.5W 24V WW IP68
Energy Efficiency Label	A
Materials	Body Sand Casting 316L Stainless Steel Diffuser Tempered Glass
LED Type	COB
LED Quantity	1
Average Lifetime	30'000 hours
Start Time from 0% to 100%	0 sec
Mercury Content	0.0 mg
Ingress Protection	IP68
IK Rating	IK06
Dimensions (d x h; d1)	Ø 35 x 42 mm; Ø 27 mm
Housing Dim. (d2 x h2; d3)	Ø 34 x 83 mm; Ø 50 mm

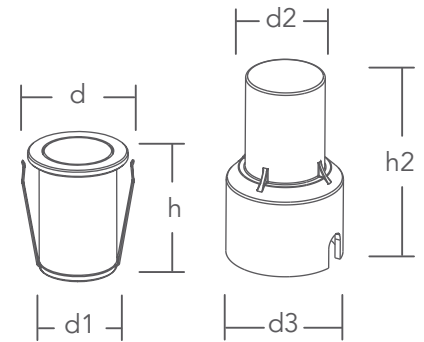

ELECTRICAL CHARACTERISTICS

System Power	1.5W
Input Voltage	24V DC



LIGHT CHARACTERISTICS

Product Reference	UL01F 1.5W/WWFL/830
Luminous Flux	100 lm
Luminous Intensity	67 lm/W
Beam Angle	120°
Colour Name	Warm White
Colour Temperature (CCT)	3'000 K
CRI	> 80